

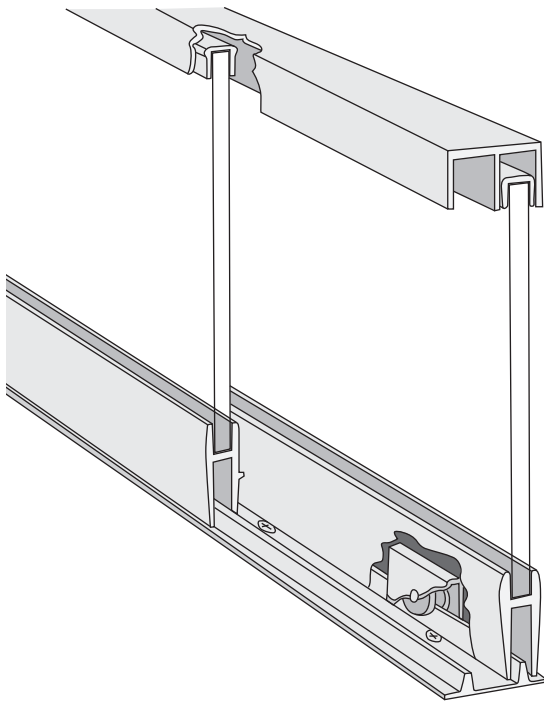

Roll-Ezy Aluminum Track for Small to Medium Sliding Glass Doors

SLIDING DOOR TRACK

- For 1/4" glass doors
- 3' to 12' lengths available



P1092 Complete Assembly

Applications

Provides smooth track system for lightweight, sliding glass doors to move back and forth with ease. Ideal for small to medium glass door installations, such as reception windows and small retail display cases.

Mounting: Recessed or Surface

Material: Anodized, corrosion free aluminum

Finishes:

Aluminum (AL): Long-lasting, corrosion resistant finish

Features:

- Installs quickly and easily with nails or glue
- Allows door to slide easily and quietly
- Can be mounted on surface or recessed
- Wide divider on upper channel maintains door position
- Components can be easily cut to fit any opening up to 12 feet
- Available in prepackaged assemblies (P1092) for 36", 48", 60" and 72" openings
- Made in the USA
- Available from open stock

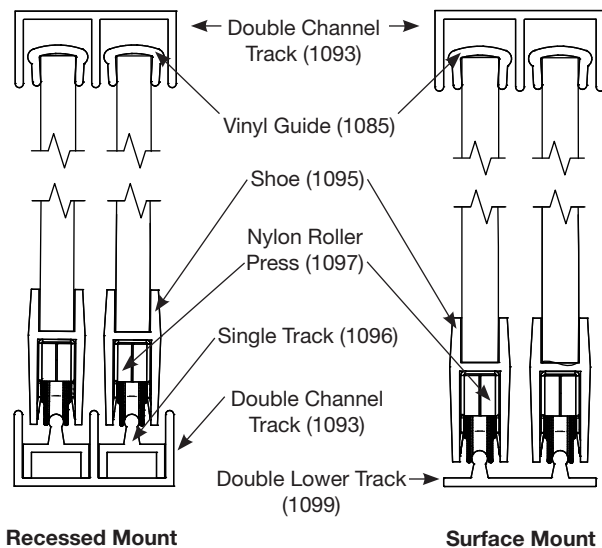

P1092 Cross Section

Roll-Ezy Aluminum Tracks - STANDARD PACKS

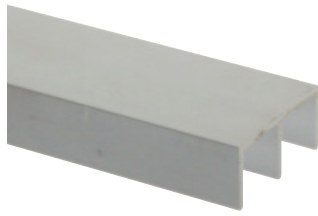

1093
Double Channel Track



1095
Shoe



1096
Single Track



1099
Double Track

Standard Packs (1/carton)							
Description	Door Size	Weight	Width	Height	Length	Aluminum (AL)	
1093 Double Channel Track (For tops, bottoms and ends.)	1/4"	0.21 lbs./ft.	1-3/16"	9/16"	144"	1093 144	
1095 Shoe (Insert rollers in bottom.)	1/4"	0.17 lbs./ft.		1"	144"	1095 144	
1096 Single Track (For single doors or use with 1093 Double Channel Track for covered installation.)	1/4"	0.09 lbs./ft.	31/64"	15/32"	144"	1096 144*	
1099 Double Lower Track	1/4"	0.12 lbs./ft.	1-1/16"	1/4"	144"	1099 144**	

*Cut glass 1-1/2" lower than opening when using 1096/1093 track.

**Cut glass 1-3/16" lower than opening when using 1099 track.

Accessories



1085 VINYL
Vinyl Guide



1087 RUB
Rubber Bumper



1097 NYLON
Nylon Roller Press



1098 ZC
Steel Ball Bearing Roller Press

Enclosed Sheaves							
Description	Packed	Weight	Size	Vinyl (VINYL)	Rubber (RUB)	Nylon (NYLON)	Zinc (ZC)
1085 Vinyl Guide (Fits over top of glass for noiseless operation in upper channel.)	100/ carton	0.26 lbs./ carton	7/8" long	1085 VINYL	-	-	-
1087 Rubber Bumper (Installs in jambs to cushion glass.)	100/ carton	0.10 lbs./ carton	-	-	1087 RUB	-	-
1097 Nylon Roller Press (Fits into bottom of 1095 shoe.)	100/ carton	0.90 lbs./ carton	-	-	-	1097 NYLON	-
1098 Steel Ball Bearing Roller Press (Fits into bottom of 1095 shoe.)	20/box	0.36 lbs./ carton	-	-	-	-	1098 ZC

Roll-Ezy Aluminum Tracks - PACKAGED ASSEMBLIES

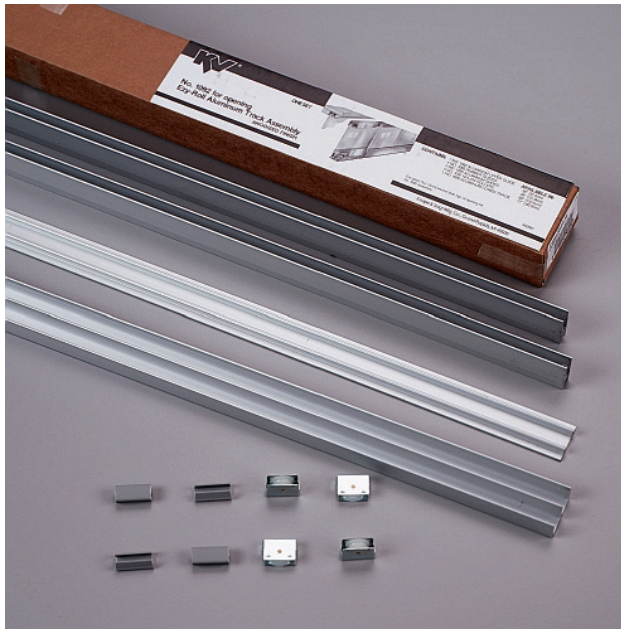

**P1092
Complete Assembly Pack**

P1092 Complete Assembly Packs (1 set/carton)		
Each Set Contains:	Track Length	Aluminum (AL)
1 - Double Channel Upper Track (1093)	36"	P1092 ANOD 36
4 - Nylon Roller Press (1097)	48"	P1092 ANOD 48
4 - Vinyl Guide (1085)	60"	P1092 ANOD 60
2 - Shoe (1095)	72"	P1092 ANOD 72
1 - Double Lower Track (1099)		

Knape & Vogt does not recommend butt-joints and/or openings longer than 12 feet. Knape & Vogt recommends that the height to width ratio for glass doors should not exceed 2:1.

Installation

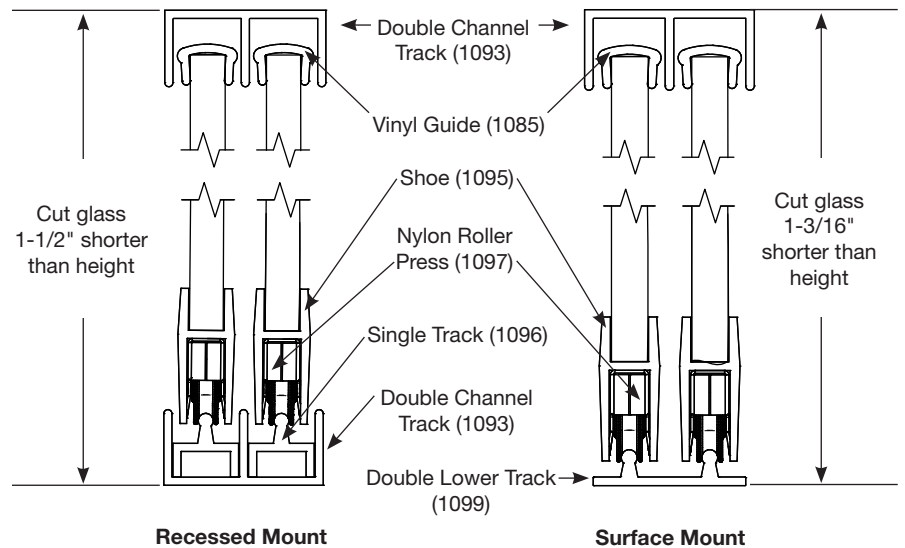
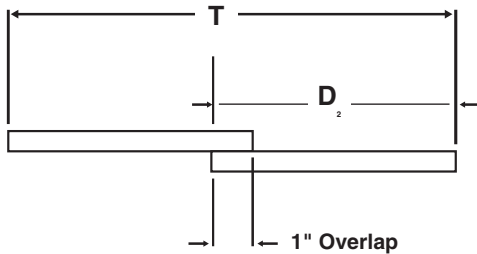

Roll-Ezy Aluminum Track for Small to Medium Sliding Glass Doors

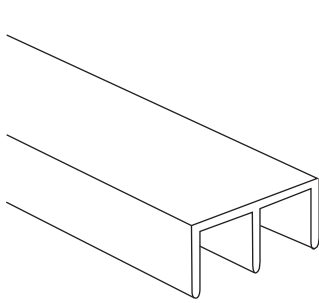

1093
Double Channel Track

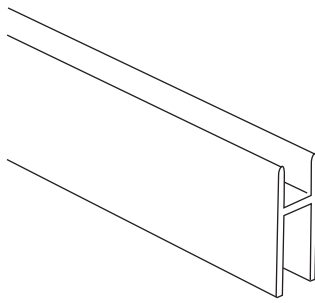

1095
Shoe

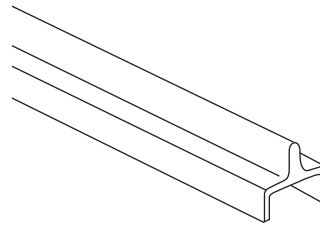

1096
Single Track

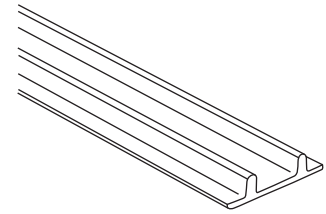

1099
Double Track

1. PRODUCT NAME

Roll-Ezy Aluminum Track for Sliding Glass Doors. Provides a smooth track system for sliding glass doors to move back and forth with ease.

2. MANUFACTURER

Knappe & Vogt
2700 Oak Industrial Dr. NE, Grand Rapids, MI USA 49505-6026
(616) 459-3311 | www.kv.com

3. PRODUCT DESCRIPTION

Basic Use: Roll-Ezy Aluminum Track for Sliding Glass Doors provide a smooth track system for sliding glass doors to move back and forth with ease. A variety of accessories are available to support glass door while gliding smoothly across metal track.

Composition and Materials: Aluminum

Sizes:

1093: 1-3/16" wide x 9/16" high x selected length

1095: 7/16" wide x 1" high x selected length

1096: 31/64" wide x 15/32" high x selected length

1099: 1-1/16" wide x 1/4" high x selected length

Lengths: 36", 48", 60", 72", 144" (some lengths not available in standard or assembly packs.)

Finishes: Aluminum (AL).

4. TECHNICAL DATA

Applicable Standards: Roll-Ezy Aluminum Track for Sliding Glass Doors are tested to meet or exceed ANSI performance standards as established by BHMA in the Knappe & Vogt™ (KV™) recommended application.

Results were obtained by laboratory testing in accordance with ANSI/ BHMA A156.9-2003 performance standard. Actual use conditions will typically result in lower load capacity than laboratory conditions.

Representative testing in a fully configured application is the only way to assure proper performance, durability, and safety.

Environmental Considerations:

Environment: Excessive humidity, salts, or other chemical agents can corrode the finish and attack metal or plastic components.

Fastening: Inadequate or incorrect fasteners can result in the track or sheave pulling loose and causing damage.

Alignment: Improper track/accessory alignment can result in a sliding door system that is ineffective and unsafe.

5. INSTALLATION

1. Lay guide and track in recessed grooves or on surface.
2. Attach with small nails or glue.
3. Height of glass door should be 1-3/16" (30.16mm) shorter than distance between top of guide and bottom of track.
4. Place top of door in guide and swing bottom of door into track.

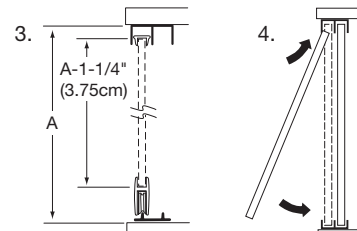

6. AVAILABILITY AND COST

Availability: Knappe & Vogt™ (KV™) products are available from stocking distributors and through KV™ Representatives worldwide.

Cost: Current pricing is available from area KV™ Representatives. Please call for the nearest representative: (800) 253-1561.

7. WARRANTY

Limited Lifetime Warranty: Knappe & Vogt offers its standard Limited Lifetime Warranty to the initial purchaser of commercial products. This warranty covers defects in materials and workmanship which occur during normal use, and the remedy is limited to repair or replacement of defective products, at KV's option. Certain types of defects and damage are excluded from warranty coverage, costs and expenses are not covered, and additional restrictions apply. A copy of the Limited Lifetime Warranty, with all warranty details, limitations and disclaimers, is available on the Customer Care Connection location at www.kv.com or from KV Customer Service, 2700 Oak Industrial Drive, Grand Rapids, MI 49505, (800) 253-1561.

8. MAINTENANCE

Roll-Ezy Aluminum Track for Sliding Glass Doors require no maintenance. Inspect for proper fit periodically and adjust when necessary. Replace as required or recommended by application.

9. TECHNICAL SERVICES

Knappe & Vogt™ and area representatives can assist with any application. For further information, or for the name of the representative nearest you, please call Knappe & Vogt™ Customer Service: (800) 253-1561 or visit our website at www.kv.com.

10. FILING SYSTEMS

Additional product information, data sheets, application sheets, and a full catalog are available upon request from Knappe & Vogt™.

BHMA *Knappe & Vogt products follow the ANSI testing standards established by BHMA.*

Knappe & Vogt reserves the right to change product specifications at any time without notice and without incurring responsibility for existing units. This information conforms to editorial style prescribed by The Construction Specifications Institute.